



## ICC-ES Listing Report ESL-1615

Issued March 2024

This listing is subject to renewal March 2025.

**CSI:** DIVISION: 07 00 00—THERMAL AND MOISTURE PROTECTION  
Section: 07 80 00—Fire and Smoke Protection  
Section: 07 84 00—Firestopping  
Section: 07 84 53—Building Perimeter Firestopping

### Product Certification System:

The ICC-ES product-certification system includes evaluating reports of tests of standard manufactured product, prepared by accredited testing laboratories and provided by the listee, to verify compliance with applicable codes and standards. The system also involves factory inspections, and assessment and surveillance of the listee's quality system.

**Product:** SIDERISE CW-FS120

**Listee:** SIDERISE INSULATION LIMITED

**Evaluation:** Siderise CW-FS120 perimeter barriers and firestops for curtain walling comprises of a 120 mm thick one-piece product with a pre-compressed noncombustible stone wool core and integral aluminum foil facing. Siderise CW-FS120 perimeter barriers and firestops for curtain walling were evaluated based on a tested non-load bearing wall assembly consisting of building-material components described in the Design Listings, tested in accordance with the following standard:

- ASTM E2307 (-20, -19 and -10), Standard Test Method for Determining Fire Resistance of Perimeter Fire Barriers Using Intermediate-Scale, Multi-story Test Apparatus.

**Findings:** Siderise CW-FS120 perimeter barriers and firestops for curtain walling as components of the assembly is based on testing in accordance with the applicable test method as referenced in each ICC Design No., and as referenced in the applicable sections of the following code editions:

- 2018 *Saudi Building Code General Requirements* (SBC 201)  
Applicable Section: 715.4

### Identification:

1. The ICC-ES mark of conformity, electronic labeling, the listing report number (ICC-ES ESL-1615), and when applicable, the ICC-ES Listing Mark, along with the name, registered trademark, or registered logo of the listee must be included in the product label.
2. In addition, Siderise CW-FS120 perimeter barriers and firestops for curtain walling are identified by a label that includes the product name, the name (Siderise Insulation Limited), and address of the manufacturer.
3. The report holder's contact information is the following:

**SIDERISE INSULATION LIMITED**  
**FORGE INDUSTRIAL ESTATE**  
**MAESTEG, BRIDGEND CF34 0AH**  
**UNITED KINGDOM**  
**+44 1656 730833**  
[www.siderise.com](http://www.siderise.com)

**Installation:** Siderise CW-FS120 perimeter barriers and firestops for curtain walling must be installed in accordance with Siderise Insulation Limited's published installation instructions and applicable codes.

**Conditions of Listing:**

1. The listing report addresses only conformance with the standards and code sections noted above.
2. Approval of the product's use is the sole responsibility of the local code official.
3. The listing applies only to the materials tested and as submitted for review by ICC-ES.
4. The perimeter joint protection described in this listing report was not subjected to movement cycling (horizontal or vertical shear) prior to fire exposure, unless noted otherwise in the ICC Design No.
5. Siderise CW-FS120 perimeter barriers and firestops for curtain walling described in this listing report are manufactured under a quality control program with inspections by ICC-ES.

**Applicant:** SIDERISE INSULATION LIMITED

**Product:** SIDERISE CW-FS120

**Standard:** ASTM E2307

**“T” Rating:** 3-Hour

**“F” Rating:** 3-Hour

TMP = Thermal and Moisture Protection

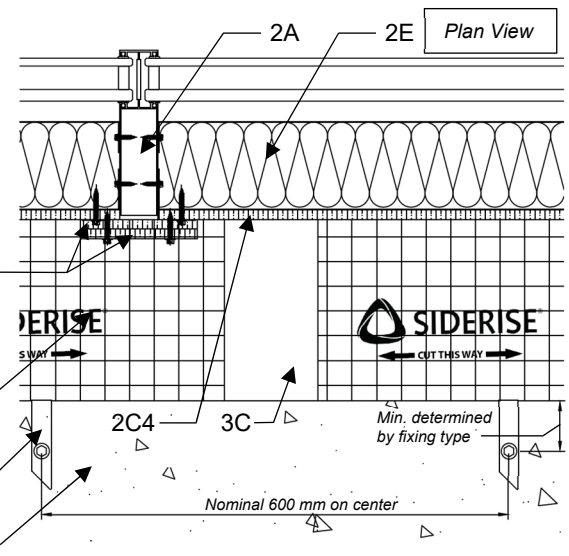
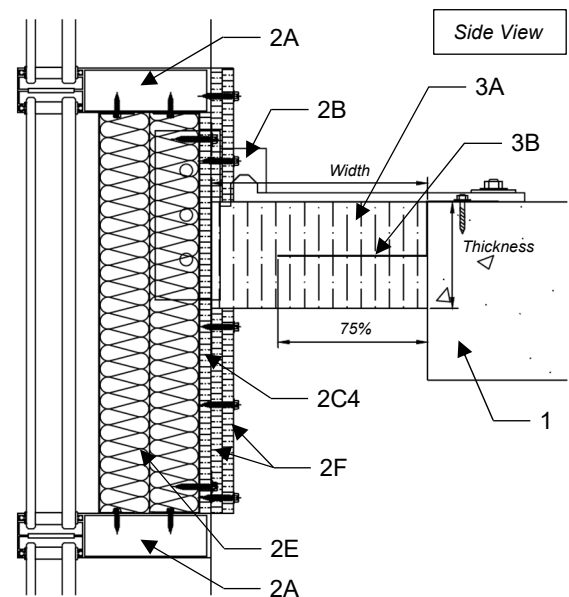
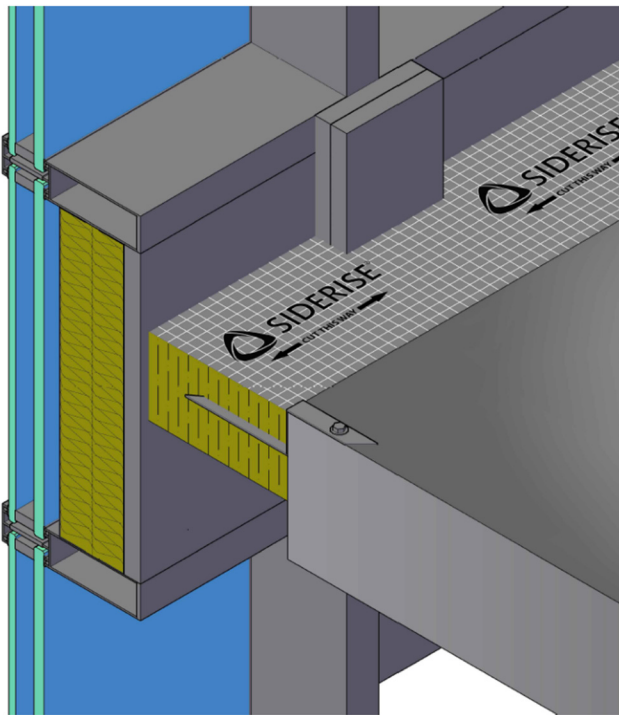

Components of Construction	
1	Floor Assembly
2A	Curtain Wall Framing
2B	Curtain Wall Bracket System
2C1	Spandrel Panel – Stud & Track Framing System (Not Shown)
2C2	Spandrel Panel – Steel Reinforcement Frame (Not Shown)
2C3	Spandrel Panel – Sheet Steel Pan (Not Shown)
2C4	Spandrel Panel – Cement Board Internal Lining
2D	Vision Panels (Not Shown)
2E	Curtain Wall Insulation
2F	Mullion Covers (Cement Board)
3A	Perimeter Seal
3B	Perimeter Seal Fixing Brackets
3C	Aluminum Jointing Tape

## COMPONENTS OF CONSTRUCTION:

ITEM NO.	COMPONENTS	MATERIALS
1	<b>Floor Assembly—</b>	Minimum 225 mm thick reinforced normal weight structural concrete with a minimum unit weight of 2000 kg/m <sup>3</sup> . Concrete floor assembly must have a 3-hour fire-resistance rating in accordance with ASTM E119.
2	<b>Curtain Wall Assembly—</b>  Note: The curtain wall assembly must incorporate construction features A through F.	<p><b>A — Curtain Wall Framing</b> – Rectangular tubing mullions (vertical members) and transoms (horizontal members) of minimum 100 mm depth and 52 mm width dimensions must be formed from minimum 2.5 mm thick aluminum. The spacing between mullions (vertical members) is not limited. The maximum separation between the interior face of the mullions and the edge of the floor assembly must be 100 mm. Transoms (horizontal members) must be spaced at a minimum of 900 mm on center. The minimum height from the top of the floor assembly to the bottom of the transom must be 750 mm.</p> <p><b>B — Curtain Wall Bracket System</b> – The mullions are secured to the top of the supporting floor assembly using a bracket-system in accordance with curtain wall system manufacturer's published installation instructions.</p> <p><b>C — Spandrel Panels</b> – The spandrel panels must incorporate the following construction features:  <b>C1 – Stud &amp; Track Framing System (Not Shown)</b> – Minimum 0.6 mm thick KNAUF galvanized steel head and floor tracks are secured to the sill and soffit of the transom members, respectively, using KNAUF LN wafer-head screws (3.5 mm diameter and 11 mm length) spaced at a nominal distance of 50 mm from the ends and 300 mm on center. KNAUF galvanized steel studs are spaced at a nominal distance of 380 mm from the ends and 405 mm on center, leaving a 5 mm gap from the inner face of the head track only. The studs are secured to the floor tracks using KNAUF LN wafer-head screws (3.5 mm diameter and 11 mm length). The abutment studs are secured to the mullion members on the vertical edges using KNAUF LN wafer-head screws (3.5 mm diameter and 11 mm length) spaced at a nominal distance of 50 mm from the ends and 300 mm on center.  <b>C2 – Steel Reinforcement Frame (Not Shown)</b> – A pre-welded galvanized steel reinforcement frame is pressure fitted onto the spandrel area and oriented with the flanges of the system slotted along the edges. The steel reinforcement frame is secured to mullion and transom members using pan-head tapping screws (4.8 mm diameter and 32 mm length) spaced 150 mm from the edges and equidistantly spaced on center.  <b>C3 – Sheet Steel Pan (Not Shown)</b> – Minimum 2 mm thick GI sheet is secured to the steel reinforcement frame using stainless-steel blind rivets (3.2 mm diameter and 10 mm length) spaced nominally at 300 mm on center along the perimeter.  <b>C4 – Cement Board Internal Lining</b> – One layer of 12.5 mm thick Knauf AQUAPANEL® Cement Board Indoor (1050 kg/m<sup>3</sup> density), used as the internal lining of spandrel area, is secured to the stud &amp; track framing system using Knauf AQUAPANEL® Maxi screws (4 mm diameter and 25 mm length) spaced horizontally at 400 mm on center and vertically at 200 mm on center. Boards must be installed horizontally and in a staggered pattern. The boards are installed horizontally and in a staggered pattern. The horizontal joint must be a minimum distance of 439 mm from the top surface of the perimeter fire barrier. The board joints (interior side) must be covered with continuous lengths of KNAUF joint tape and two layers of KNAUF joint compound applied at a nominal width of 250 mm. All fastener heads must be covered using KNAUF joint compound.</p> <p><b>D — Vision Panels (Not Shown)</b> – Two layers of 6 mm thick transparent heat-strengthened glass panes separated by a 20 mm air gap.  Use of tempered or heat-strengthened glass panes, or alternative decorative panels of suitable materials like metals, stone, marble, etc. meeting requirements of ASTM E136 are acceptable as the exterior pane.</p> <p><b>E — Curtain Wall Insulation</b> – Mineral wool insulation batts (minimum 80 kg/m<sup>3</sup> density and 75 mm thick), classified as noncombustible when tested in accordance with ASTM E136. Aluminum pins are self-adhered to the unexposed side of the cement board at a maximum vertical spacing of 280 mm on center. Pieces of the mineral wool insulation (minimum 80 kg/m<sup>3</sup> density and 75 mm thick) must be used to fill the hollow depth of the studs. The mineral wool insulation batts are impaled against the pins and fixed in place using pin caps. Firestop sealant must be applied along the perimeter edge of the pins, as well as along the edges of the mullions visible on the interior side of the curtain wall assembly prior to fixing the mineral wool insulation batts in place.</p> <p><b>F — Mullion Covers (Cement Board)</b> – Two layers of minimum 12.5 mm thick KNAUF AQUAPANEL® Cement Board Indoor, cut into 690 mm long by 200 mm wide panels, are installed vertically onto the cement board on the interior side of the curtain wall, thereby overlapping the mullion profiles along the spandrel panels. Both layers of KNAUF AQUAPANEL® Cement Board Indoor are secured using KNAUF AQUAPANEL® fasteners with diameters of 4 mm and lengths of 11 mm.</p>
3	<b>Perimeter Joint Protection—</b>  Note: The maximum separation between the edge of the floor assembly and the interior face of the framing system (curtain wall assembly) must be 100 mm. The perimeter joint protection must incorporate construction features A through C.	<p><b>A — Perimeter Seal</b>– 120 mm thick Siderise CW-FS120 reinforced aluminum foil-faced lamella boards (nominal 75 kg/m<sup>3</sup> density) must be used in the gap between the edge of the floor assembly and the face of the framing system. Lamella boards must be compressed 20% and installed with mineral fiber grains oriented vertically (with aluminum foil-facings on top and bottom).</p> <p><b>B — Perimeter Seal Fixing Brackets</b> – Siderise CW-FS120 boards must be fixed to the reinforced concrete floor assembly with 1 mm thick, 25 mm wide galvanized steel fixing brackets (Z-shaped profile formed and installed in accordance with Siderise's published installation instructions) impaled into the Siderise CW-FS120 board (75% of total void size) at 300 mm from their extremities (200 mm if close to a fixation of the curtain wall assembly), and maximum spacing of 600 mm on center between brackets. The fixing brackets must be secured to the concrete floor assembly using noncombustible fasteners (4.3 mm diameter and 16 mm length).</p> <p><b>C — Aluminum Jointing Tape</b> – All splices and butt joints between Siderise CW-FS120 boards must be covered by Siderise RFT120 self-adhesive aluminum jointing foil tape.</p>

For Imperial Units: 1 mm = 0.039 in; 1 kg/m<sup>3</sup> = 0.062 lbs./ft<sup>3</sup>

**Applicant:** SIDERISE INSULATION LIMITED

**Product:** SIDERISE CW-FS120

**Standard:** ASTM E2307

**“T” Rating:** 2 1/2-Hour

**“F” Rating:** 3-Hour

TMP = Thermal and Moisture Protection

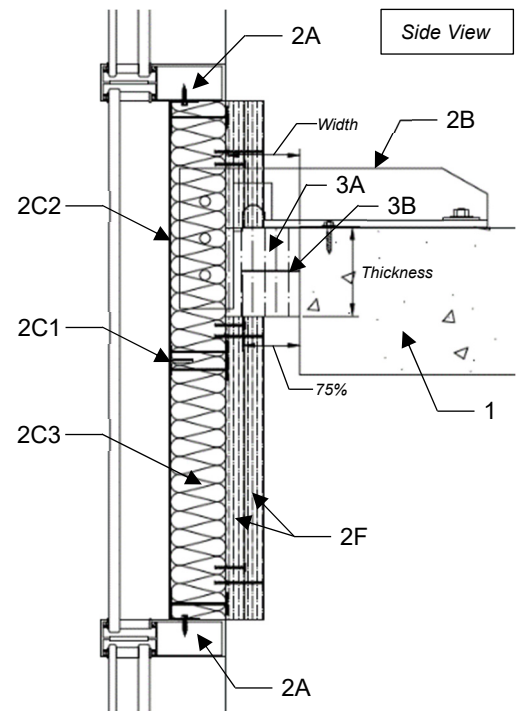
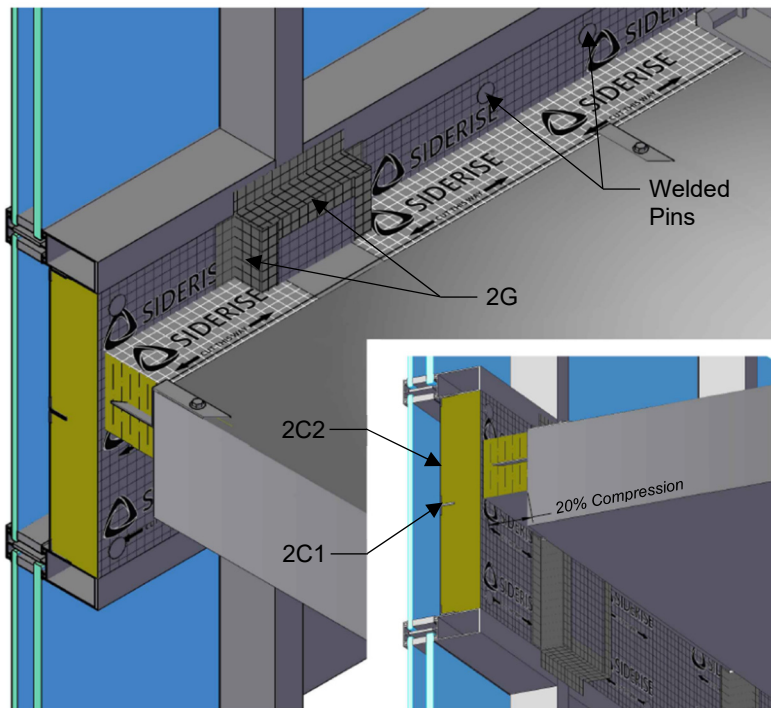

Components of Construction	
1	Floor Assembly
2A	Curtain Wall Framing
2B	Curtain Wall Bracket System
2C1	Spandrel Panel – Steel Reinforcement Frame
2C2	Spandrel Panel – Sheet Steel Pan
2C3	Spandrel Panel – Spandrel Insulation
2D	Vision Panels (Not Shown)
2E1	Curtain Wall Sheet Steel Tray (Not Shown)
2E2	Curtain Wall Insulation (Not Shown)
2F	Mullion Covers
2G	Aluminum Jointing Tape
3A	Perimeter Seal
3B	Perimeter Seal Fixing Brackets
3C	Aluminum Jointing Tape

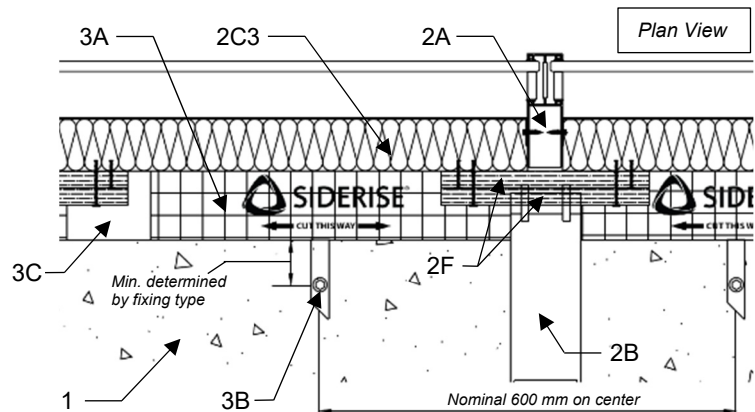

**COMPONENTS OF CONSTRUCTION:**

ITEM NO.	COMPONENTS	MATERIALS
1	<b>Floor Assembly—</b>	Minimum 203 mm thick reinforced normal weight structural concrete with a minimum unit weight of 2000 kg/m <sup>3</sup> . Concrete floor assembly must have a 3-hour fire-resistance rating in accordance with ASTM E119. Ceramic fiber insulation of minimum density 128 kg/m <sup>3</sup> must be fixed to the underside of the floor assembly.
2	<b>Curtain Wall Assembly—</b> Note: The curtain wall assembly must incorporate construction features A through G.	<p><b>A — Curtain Wall Framing</b> – Rectangular tubing mullions (vertical members) and transoms (horizontal members) of minimum 100 mm depth and 52 mm width dimensions must be formed from minimum 2.5 mm thick aluminum. Mullions (vertical members) spaced maximum 1483 mm on center. The maximum separation between the interior face of the mullions and the edge of the floor assembly must be 100 mm. Transoms (horizontal members) must be spaced at a minimum of 1018 mm on center vertically. The minimum height from the top of the concrete floor assembly to the bottom of the transom must be 202 mm.</p> <p>The mullions (vertical members) can be constructed as solid members, or as joining members that are split vertically. Joining members must use galvanized steel rectangular hollow sections (RHS) inserted into the mullions at the splice joint with at least 395 mm of overlap between the mullions and RHS on each half of the splice joint. The RHS must be secured to each mullion on each side of the splice joint using three (3) pan head tapping screws (4.8 mm diameter and 32 mm length) spaced nominally at 25 mm from the edges of the splice joint and 175 mm on center elsewhere. The 10 mm splice joint on all mullions must be covered with Tritosil W70 FR fire rated silicone sealant.</p> <p><b>B — Curtain Wall Bracket System</b> – The mullions are secured to the top of the supporting floor assembly using a bracket-system in accordance with curtain wall system manufacturer’s published installation instructions.</p> <p><b>C — Spandrel Panels</b> – The spandrel panels must incorporate the following construction features:</p> <p><b>C1 – Steel Reinforcement Frame</b> – A pre-welded galvanized steel reinforcement frame consisting of perimeter L-shaped angles (50 mm by 65 mm by 1.8 mm thick) is secured to the transom and mullions profiles at a distance of 25 mm from the exterior face of the transom and mullion profiles. The steel reinforcement frame must be secured using stainless-steel pan head tapping screws (4.3 mm diameter and 16 mm length) spaced nominally at 300 mm on center along the perimeter. Once perimeter framing is secured, two additional L-shaped angles (25 mm by 40 mm by 1.5 mm thick) are installed back-to-back forming a “T” shape and secured to the vertical reinforcement framing members at mid-height using four (4) stainless-steel blind rivets (3 mm diameter and 8 mm length). A 25 mm by 20 mm by 1.5 mm thick L-shaped angle cleat must be secured to the mid-height reinforcement angles and secured to the vertical mullions using stainless-steel blind rivets (3 mm diameter and 8 mm length).</p> <p><b>C2 – Sheet Steel Pan</b> – Minimum 1.5 mm thick galvanized sheet steel trays are secured to the perimeter L-angle framing of the steel reinforcement frame using stainless-steel blind rivets (3 mm diameter and 8 mm length) spaced nominally at 300 mm on center along the perimeter.</p> <p><b>C3 – Spandrel Insulation</b> – One layer of 75 mm thick Siderise CW-SI (Curtain Wall Spandrel Insulation), with a minimum 128 kg/m<sup>3</sup> density, is installed on the interior face of the curtain wall and fixed to the perimeter and mid-height L-shaped angles using welded galvanized steel pins (30 mm diameter and 1.5 mm thick pin base, 75 mm depth and 2 mm thick pin dimensions). The steel pins must be spaced a maximum of 50.8 mm from the perimeter of the reinforcement frame and maximum 304.8 on center. Siderise RFT120 self-adhesive aluminum jointing tape must be applied along the perimeter edges, splice joints, and over the welded pins of the spandrel insulation.</p> <p><b>D — Vision Panels (Not Shown)</b> – Two layers of 6 mm thick transparent heat-strengthened glass panes separated by a 20 mm air gap. Use of tempered or heat-strengthened glass panes, or alternative decorative panels of suitable materials like metals, stone, marble, etc. meeting requirements of ASTM E136 are acceptable as the exterior pane.</p> <p><b>E — Curtain Wall Insulation System</b> – The curtain wall insulation system must incorporate the following construction features:</p> <p><b>E1 – Curtain Wall Sheet Steel Tray (Not Shown)</b> – Minimum 1.5 mm thick galvanized sheet steel trays are secured to the transom and mullions profiles at a distance of 20 mm from the interior end of the curtain wall assembly. Trays must be secured using stainless-steel pan head tapping screws (4.3 mm diameter and 16 mm length) spaced nominally at 300 mm on center along the perimeter.</p> <p><b>E2 – Curtain Wall Insulation (Not Shown)</b> – One layer of 75 mm thick Siderise CW-SI (Curtain Wall Spandrel Insulation), with a minimum 128 kg/m<sup>3</sup> density, must be fixed to the sheet steel tray using welded galvanized steel pins (30 mm diameter and 1.5 mm thick pin base, 75 mm depth and 2 mm thick pin dimensions). The steel pins must be spaced a maximum of 50.8 mm from the perimeter of the sheet steel tray and maximum 304.8 mm on center.</p> <p><b>F — Mullion Covers</b> – Two layers of minimum 25 mm thick Siderise CW-FB (Curtain Wall Fire Board), with a minimum density of 160 kg/m<sup>3</sup>, cut into 966 mm long by 200 mm wide panels, are installed vertically onto the Siderise CW-SI (Curtain Wall Spandrel Insulation) on the interior side of the curtain wall, thereby overlapping the mullion profiles along the spandrel panels. The base layer of Siderise CW-FB is secured to the layer of CW-SI using 40 mm long Spiral Screws spaced 250 mm on center vertically. The face layer of Siderise CW-FB is secured through the base layer to the layer of CW-SI using 65 mm long Spiral Screws spaced 250 mm on center vertically and staggered from the base layer screws.</p> <p><b>G — Aluminum Jointing Tape</b> – All exposed edges of the mullion covers, and the interface of the mullion covers and spandrel panels must be covered by Siderise RFT120 self-adhesive aluminum jointing tape.</p>
3	<b>Perimeter Joint Protection—</b> Note: The maximum separation between the edge of the floor assembly and the interior face of the framing system (curtain wall assembly) must be 100 mm. The perimeter joint protection must incorporate construction features A through C.	<p><b>A — Perimeter Seal</b>– 120 mm thick Siderise CW-FS120 reinforced aluminum foil-faced lamella boards (nominal 75 kg/m<sup>3</sup> density) must be used in the gap between the edge of the floor assembly and the face of the framing system. Lamella boards must be compressed 20% and installed with mineral fiber grains oriented vertically (with aluminum foil-facings on top and bottom).</p> <p><b>B — Perimeter Seal Fixing Brackets</b> – Siderise CW-FS120 boards must be fixed to the reinforced concrete floor assembly with 1 mm thick, 25 mm wide Siderise B65 galvanized steel fixing brackets (Z-shaped profile formed and installed in accordance with Siderise’s published installation instructions) impaled into the Siderise CW-FS120 board (75% of total void size) at 300 mm from their extremities (200 mm if close to a fixation of the curtain wall assembly), and maximum spacing of 600 mm on center between brackets. The fixing brackets must be secured to the concrete floor assembly using noncombustible fasteners (6.3 mm diameter and 45 mm length).</p> <p><b>C — Aluminum Jointing Tape</b> – All splices and butt joints between Siderise CW-FS120 boards must be covered by Siderise RFT120 self-adhesive aluminum jointing tape.</p>

For Imperial Units: 1 mm = 0.039 in; 1 kg/m<sup>3</sup> = 0.062 lbs./ft<sup>3</sup>.

**Applicant:** SIDERISE INSULATION LIMITED

**Product:** SIDERISE CW-FS120

**Standard:** ASTM E2307

**“T” Rating:** 1-Hour

**“F” Rating:** 2-Hour

TMP = Thermal and Moisture Protection

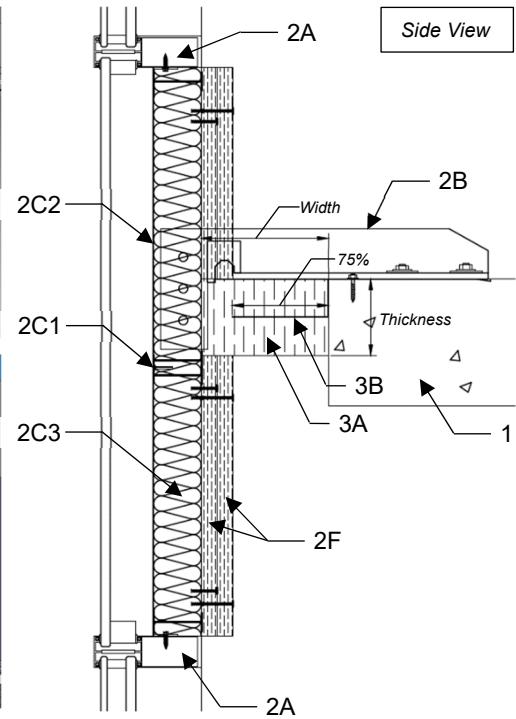
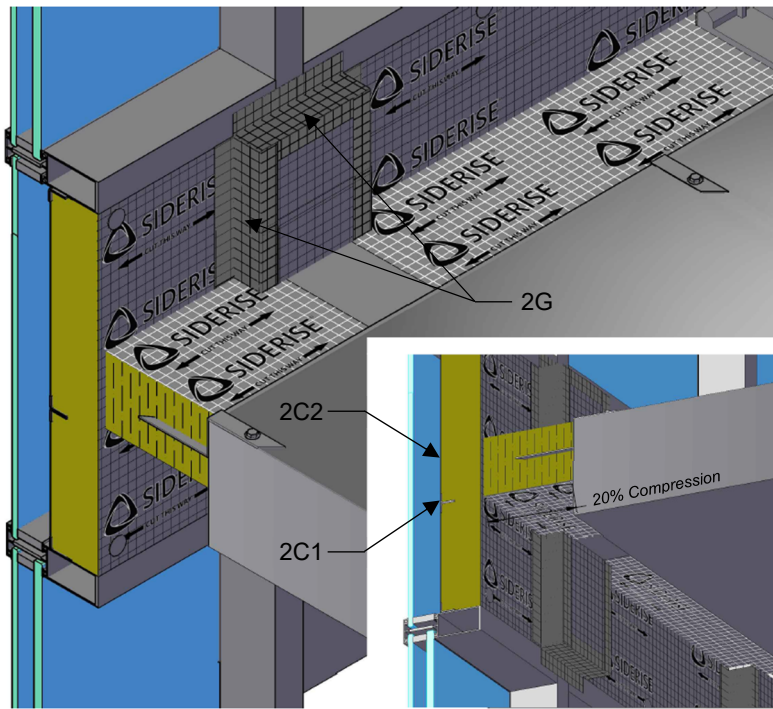

Components of Construction	
1	Floor Assembly
2A	Curtain Wall Framing
2B	Curtain Wall Bracket System
2C1	Spandrel Panel – Steel Reinforcement Frame
2C2	Spandrel Panel – Sheet Steel Pan
2C3	Spandrel Panel – Spandrel Insulation
2D	Vision Panels (Not Shown)
2E1	Curtain Wall Sheet Steel Tray (Not Shown)
2E2	Curtain Wall Insulation (Not Shown)
2F	Mullion Covers
2G	Aluminum Jointing Tape
3A	Perimeter Seal
3B	Perimeter Seal Fixing Brackets
3C	Aluminum Jointing Tape

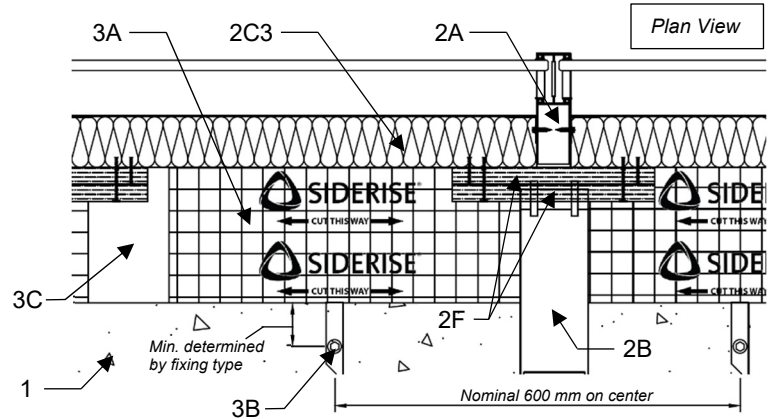

**COMPONENTS OF CONSTRUCTION:**

ITEM NO.	COMPONENTS	MATERIALS
1	<b>Floor Assembly—</b>	Minimum 203 mm thick reinforced normal weight structural concrete with a minimum unit weight of 2000 kg/m <sup>3</sup> . Concrete floor assembly must have a 2-hour fire-resistance rating in accordance with ASTM E119.
2	<b>Curtain Wall Assembly—</b> Note: The curtain wall assembly must incorporate construction features A through G.	<p><b>A — Curtain Wall Framing</b> – Rectangular tubing mullions (vertical members) and transoms (horizontal members) of minimum 100 mm depth and 52 mm width dimensions must be formed from minimum 2.5 mm thick aluminum. Mullions (vertical members) spaced maximum 1483 mm on center. The maximum separation between the interior face of the mullions and the edge of the floor assembly must be 200 mm. Transoms (horizontal members) must be spaced at a minimum of 1500 mm on center vertically. The minimum height from the top of the concrete floor assembly to the bottom of the transom must be 687 mm.</p> <p>The mullions (vertical members) can be constructed as solid members, or as joining members that are split vertically. Joining members must use galvanized steel rectangular hollow sections (RHS) inserted into the mullions at the splice joint with at least 395 mm of overlap between the mullions and RHS on each half of the splice joint. The RHS must be secured to each mullion on each side of the splice joint using three (3) pan head tapping screws (4.8 mm diameter and 32 mm length) spaced nominally at 25 mm from the edges of the splice joint and 175 mm on center elsewhere. The 10 mm splice joint on all mullions must be covered with Tritosil W70 FR fire rated silicone sealant.</p> <p><b>B — Curtain Wall Bracket System</b> – The mullions are secured to the top of the supporting floor assembly using a bracket-system in accordance with curtain wall system manufacturer’s published installation instructions.</p> <p><b>C — Spandrel Panels</b> – The spandrel panels must incorporate the following construction features:</p> <p><b>C1 – Steel Reinforcement Frame</b> – A pre-welded galvanized steel reinforcement frame consisting of perimeter L-shaped angles (50 mm by 65 mm by 1.5 mm thick) is secured to the transom and mullion profiles at a distance of 5 mm from the interior face of the transom and mullion profiles. The steel reinforcement frame must be secured using stainless-steel pan head tapping screws (4.3 mm diameter and 16 mm length) spaced nominally at 300 mm on center along the perimeter. Once perimeter framing is secured, additional L-shaped angles (25 mm by 40 mm by 1.5 mm thick) are installed back-to-back forming a T-shape and secured to the vertical reinforcement framing members. Three sets of T-shaped horizontal members are evenly spaced vertically and secured using four (4) stainless-steel blind rivets (3 mm diameter and 8 mm length). A 25 mm by 20 mm by 1.5 mm thick L-shaped angle cleat must be secured to each of the three T-shaped horizontal members and secured to the vertical mullions using stainless-steel blind rivets (3 mm diameter and 8 mm length).</p> <p><b>C2 – Sheet Steel Pan</b> – Minimum 1.5 mm thick galvanized sheet steel trays are secured to the perimeter L-angle framing of the steel reinforcement frame using stainless-steel blind rivets (3 mm diameter and 8 mm length) spaced nominally at 300 mm on center along the perimeter.</p> <p><b>C3 – Spandrel Insulation</b> – One layer of 75 mm thick Siderise CW-SI (Curtain Wall Spandrel Insulation), with a minimum 128 kg/m<sup>3</sup> density, is installed on the interior face of the curtain wall and fixed to the perimeter L-shaped angles and intermediate T-shaped members using welded galvanized steel pins (30 mm diameter and 1.5 mm thick pin base, 75 mm depth and 2 mm thick pin dimensions). The steel pins must be spaced a maximum of 2-inches from the perimeter of the reinforcement frame and maximum 304.8 mm on center. Siderise RFT120 self-adhesive aluminum jointing tape must be applied along the perimeter edges, splice joints, and over the welded pins of the spandrel insulation.</p> <p><b>D — Vision Panels (Not Shown)</b> – Two layers of 6 mm thick transparent heat-strengthened glass panes separated by a 20 mm air gap. Use of tempered or heat-strengthened glass panes, or alternative decorative panels of suitable materials like metals, stone, marble, etc. meeting requirements of ASTM E136 are acceptable as the exterior pane.</p> <p><b>E — Curtain Wall Insulation System</b> – The curtain wall insulation system must incorporate the following construction features:</p> <p><b>E1 – Curtain Wall Sheet Steel Tray (Not Shown)</b> – Minimum 1.5 mm thick galvanized sheet steel trays are secured to the transom and mullions profiles at a distance of 25 mm from the interior end of the curtain wall assembly. Trays must be secured using stainless-steel pan head tapping screws (4.3 mm diameter and 16 mm length) spaced nominally at 300 mm on center along the perimeter.</p> <p><b>E2 – Curtain Wall Insulation (Not Shown)</b> – One layer of 75 mm thick Siderise CW-SI (Curtain Wall Spandrel Insulation), with a minimum 128 kg/m<sup>3</sup> density, must be fixed to the sheet steel tray using welded galvanized steel pins (30 mm diameter and 1.5 mm thick pin base, 75 mm depth and 2 mm thick pin dimensions). The steel pins must be spaced a maximum of 50.8 mm from the perimeter of the sheet steel tray and maximum 304.8 mm on center.</p> <p><b>F — Mullion Covers</b> – Two layers of minimum 25 mm thick Siderise CW-FB (Curtain Wall Fire Board), with a minimum density of 160 kg/m<sup>3</sup>, cut into 1448 mm long by 200 mm wide panels, are installed vertically onto the Siderise CW-SI (Curtain Wall Spandrel Insulation) on the interior side of the curtain wall, thereby overlapping the mullion profiles along the spandrel panels. The base layer of Siderise CW-FB is secured to the layer of CW-SI using 40 mm long Spiral Screws spaced 250 mm on center vertically. The face layer of Siderise CW-FB is secured through the base layer to the layer of CW-SI using 65 mm long Spiral Screws spaced 250 mm on center vertically and staggered from the base layer screws.</p> <p><b>G — Aluminum Jointing Tape</b> – All exposed edges of the mullion covers, and the interface of the mullion covers and spandrel panels must be covered by Siderise RFT120 self-adhesive aluminum jointing tape.</p>
3	<b>Perimeter Joint Protection—</b> Note: The maximum separation between the edge of the floor assembly and the interior face of the framing system (curtain wall assembly) must be 200 mm. The perimeter joint protection must incorporate construction features A through C.	<p><b>A — Perimeter Seal</b>– 120 mm thick Siderise CW-FS120 reinforced aluminum foil-faced lamella boards (nominal 75 kg/m<sup>3</sup> density) must be used in the gap between the edge of the floor assembly and the face of the framing system. Lamella boards must be compressed 20% and installed with mineral fiber grains oriented vertically (with aluminum foil-facings on top and bottom).</p> <p><b>B — Perimeter Seal Fixing Brackets</b> – Siderise CW-FS120 boards must be fixed to the reinforced concrete floor assembly with 1 mm thick, 25 mm wide Siderise B195 galvanized steel fixing brackets (Z-shaped profile formed and installed in accordance with Siderise’s published installation instructions) impaled into the Siderise CW-FS120 board (75% of total void size) at 300 mm from their extremities (200 mm if close to a fixation of the curtain wall assembly), and maximum spacing of 600 mm on center between brackets. The fixing brackets must be secured to the concrete floor assembly using noncombustible fasteners (6.3 mm diameter and 45 mm length).</p> <p><b>C — Aluminum Jointing Tape</b> – All splices and butt joints between Siderise CW-FS120 boards must be covered by Siderise RFT120 self-adhesive aluminum jointing tape.</p>

For Imperial Units: 1 mm = 0.039 in; 1 kg/m<sup>3</sup> = 0.062 lbs./ft<sup>3</sup>.